

RAK2287 WisLink LPWAN Concentrator Datasheet

Overview

Description

The **RAK2287** is an LPWAN Concentrator Module with a mini-PCIe form factor based on Semtech SX1302, facilitating easy integration into an existing router or other network equipment with LPWAN Gateway capabilities. It can be utilized in any embedded platform offering a free mini-PCIe slot with SPI connection. Additionally, the **ZOE-M8Q GPS chip** is integrated on board.

This module offers an exceptional, comprehensive, and cost-efficient gateway solution. It provides up to 10 programmable parallel demodulation paths, an 8 x 8 channel LoRa packet detector, 8 x SF5-SF12 LoRa demodulators, and 8 x SF5-SF10 LoRa demodulators.

Additionally, RAK2287 can detect an uninterrupted combination of packets at 8 different spreading factors and 10 channels. It can continuously demodulate up to 16 packets, making it suitable for smart metering fixed networks and Internet-of-Things (IoT) applications. It can cover up to 500 nodes per km² in an environment with moderate interference.

Features

- Designed based on **Mini PCI-e form factor** with a heat sink
- **SX1302 base band processor** emulates 8 x 8 channels LoRa packet detectors, 8 x SF5-SF12 LoRa demodulators, 8 x SF5-SF10 LoRa demodulators, one 125/250/500 kHz high-speed LoRa demodulator and one (G) FSK demodulator
- 3.3 V **Mini PCI-e**, compatible with 3G/LTE card of Mini PCI-e type
- Compatible with **3G/LTE card** of Mini PCI-e type
- Tx power up to 27 dBm, Rx sensitivity down to -139 dBm @ SF12, BW 125 kHz
- Supports **global license-free frequency band** (EU868, EU433, CN470, US915, AS923, AU915, KR920, and IN865)
- Supports optional SPI interfaces
- Built-in **ZOE-M8Q GPS** module

Specifications

Overview

The overview shows the top and back views of the RAK2287 board. It also presents the block diagram that discusses how the board works.

Board Overview

The RAK2287 is a compact LPWAN Gateway Module, making it suitable for integration in systems where mass and size constraints are essential. It has been designed with the PCI Express Mini Card form factor in mind, so it can easily become a part of products that comply with the standard, where they allow cards with a thickness of at least 10.5 mm.

The board has two UFL interfaces for the LoRa and GNSS antennas and a standard 52-pin connector (mPCIe).

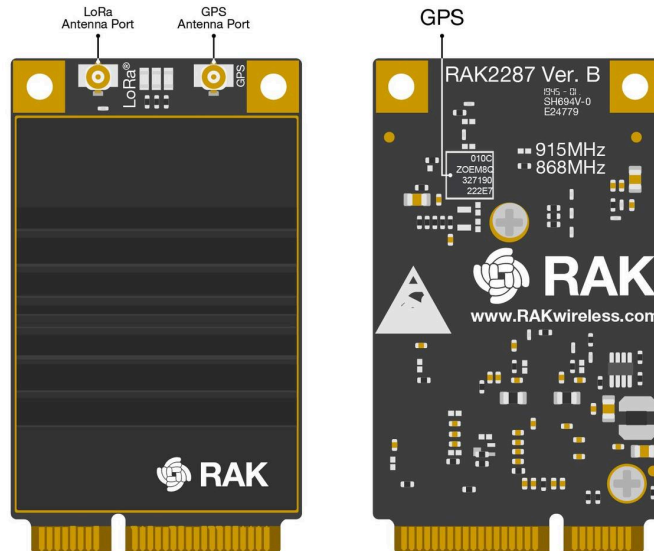

Figure 1: RAK2287 Board Overview

Block Diagram

The RAK2287 card is equipped with one SX1302 chip and two SX1250 chips. The SX1302 chip is used for RF signal processing and serves as the core of the device, while the SX1250 chips handle the related LoRa modem and processing functionalities. Additional signal conditioning circuitry is implemented to comply with the PCI Express Mini Card standard, and one UFL connector is provided for the integration of external antennas.

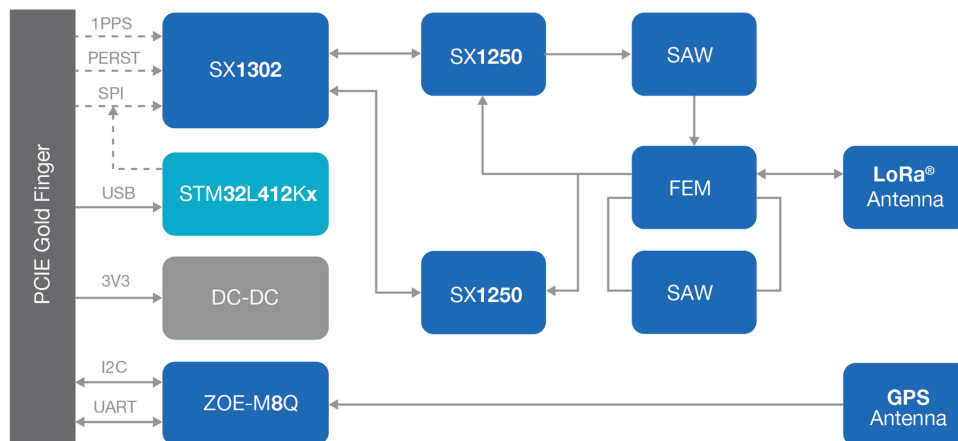

Figure 2: RAK2287 Block Diagram

Hardware

The hardware is categorized into seven (7) parts. It discusses the interfacing, pinouts and its corresponding functions and diagrams. It also covers the parameters and standard values of the board.

Interface

Power Supply

The RAK2287 card must be powered through the 3.3 Vaux pins by a DC power supply. It is crucial that the voltage remains stable, as the current drawn can vary significantly during operation, depending on the power consumption profile of the SX1302 chip. For more detailed information, refer to the [SX1302 Datasheet](#).

SPI Interface

SPI interface mainly provides for the Host_SCK, Host_MISO, Host_MOSI, Host_CSN pins of the system connector. The SPI interface gives access to the configuration register of SX1302 via a synchronous full-duplex protocol. Only the slave side is implemented.

UART and I2C Interface

The RAK2287 integrates a ZOE-M8Q GPS module, which supports both UART and I2C interfaces. The pins on the golden finger provide connections for UART and I2C, allowing direct access to the GPS module. The PPS (Pulse Per Second) signal is connected internally to the SX1302, as well as to the golden finger, making it available for use by the host board.

GPS_PPS

The RAK2287 card includes the GPS_PPS input for received packets time-stamped.

RESET

The RAK2287 card includes the RESET active-high input signal to reset the radio operations as specified by the SX1302 Specification.

Antenna RF Interface

The modules have one RF interface over a standard UFL connector (Hirose U. FL-R-SMT) with a characteristic impedance of 50 Ω. The RF port (J1) supports both Tx and Rx, providing the antenna interface.

Pin Definition

Pinout Diagram

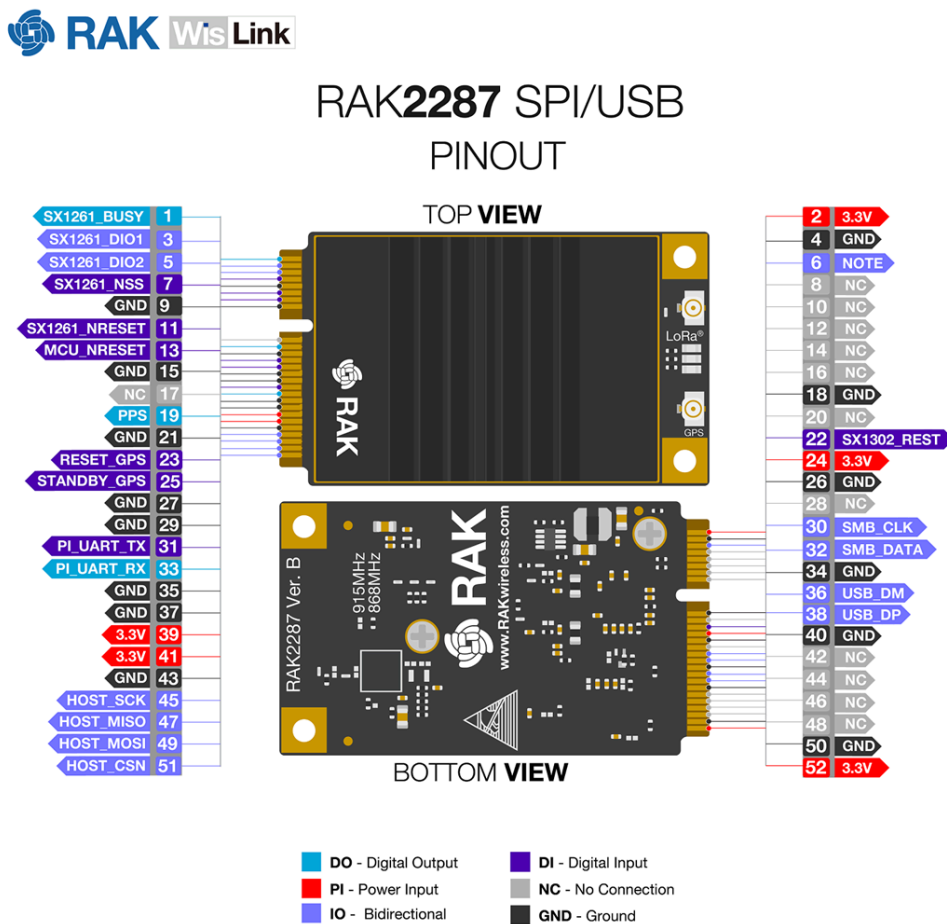

Figure 3: RAK2287 Pinout Diagram
Pinout Description

Type	Description
IO	Bidirectional
DI	Digital input
DO	Digital output
OC	Open collector
OD	Open drain
PI	Power input
PO	Power output
NC	No Connection

Pin Number	Mini PCIe Pin Rev. 2.0	RAK2287 Pin	Type	Description	Remarks
1	WAKE#	NC		No Connection	
2	3.3Vaux	3V3	PI	3.3 V _{DC} supply	
3	COEX1	NC		No Connection	
4	GND	GND		Ground	
5	COEX2	NC		No Connection	
6	1.5 V	GPIO(6)	IO		Connect to SX1302' s GPIO [6].
7	CLKREQ#	NC		No Connection	
8	UIM_PWR	NC		No Connection	
9	GND	GND		Ground	
10	UIM_DATA	NC		No Connection	
11	REFCLK-	NC		No Connection	
12	UIM_CLK	NC		No Connection	
13	REFCLK+	MCU_NRESET	DI	No Connection by default	Reserved for future applications
14	UIM_RESET	NC		No Connection	
15	GND	GND		Ground	
16	UIM_VPP	NC		No Connection	
17	RESERVED	NC		No Connection	

Pin Number	Mini PCIe Pin Rev. 2.0	RAK2287 Pin	Type	Description	Remarks
18	GND	GND		Ground	
19	RESERVED	PPS	DO	Time pulse output	Leave open if not used.
20	W_DISABLE#	NC		No Connection	
21	GND	GND		Ground	
22	PERST#	SX1302_RESET	DI	RAK2287 reset input	Active high, ≥ 100 ns for SX1302 reset.
23	PERn0	RESET_GPS	DI	GPS module ZOE-M8Q reset inputs	Active low, Leave open if not used.
24	3.3Vaux	3V3	PI	3.3 V _{DC} supply	
25	PERp0	STANDBY_GPS	DI	GPS module ZOE-M8Q external interrupt input	Active low, Leave open if not used.
26	GND	GND		Ground	
27	GND	GND		Ground	
28	1.5 V	NC		No Connection	
29	GND	GND		Ground	
30	SMB_CLK	I2C_SCL	IO	HOST SCL	Connect to GPS module ZOE-M8Q's SCL internally. Leave open if not used.
31	PETn0	PI_UART_TX	DI	HOST UART_TX	Connect to GPS module ZOE-M8Q's UART_RX internally. Leave open if not used.
32	SMB_DATA	I2C_SDA	IO	HOST SDA	Connect to GPS module ZOE-M8Q's SDA internally. Leave open if not used.
33	PETp0	PI_UART_RX	DO	HOST UART_RX	Connect to GPS module ZOE-M8Q's UART_TX internally. Leave open if not used.
34	GND	GND		Ground	
35	GND	GND		Ground	
36	USB_D-	USB_DM	IO	USB differential data (-)	Require differential impedance of 90 Ω .
37	GND	GND		Ground	
38	USB_D+	USB_DP	IO	USB differential data (+)	Require differential impedance of 90 Ω .
39	3.3Vaux	3V3	PI	3.3 V _{DC} supply	
40	GND	GND		Ground	
41	3.3Vaux	3V3	PI	3.3 V _{DC} supply	
42	LED_WWAN#	NC		No Connection	

Pin Number	Mini PCIe Pin Rev. 2.0	RAK2287 Pin	Type	Description	Remarks
43	GND	GND		Ground	
44	LED_WLAN#	NC		No Connection	
45	RESERVED	HOST_SCK	I/O	Host SPI CLK	
46	LED_WPAN#	NC		No Connection	
47	RESERVED	HOST_MISO	I/O	Host SPI MISO	
48	1.5 V	NC		No Connection	
49	RESERVED	HOST_MOSI	I/O	Host SPI MOSI	
50	GND	GND		Ground	
51	RESERVED	HOST_CSN	I/O	Host SPI CS	
52	3.3Vaux	3V3	PI	3.3 V _{DC} supply	

RF Characteristics

Operating Frequencies

The board supports the following LoRaWAN frequency channels, allowing easy configuration while building the firmware from the source code.

Region	Frequency (MHz)
Europe	EU868 EU433
North America	US915
Asia	AS923
Australia	AU915
Korea	KR920
Indian	IN865
China	CN470

RF Characteristics

The following table gives typically sensitivity level of the RAK2287 card.

Signal Bandwidth / [kHz]	Spreading Factor	Sensitivity / [dBm]
125	12	-139
125	7	-125
250	7	-123

Signal Bandwidth / [kHz]	Spreading Factor	Sensitivity / [dBm]
500	12	-134
500	7	-120

Electrical Requirements

Exceeding one or more of the limits specified in the Absolute Maximum Rating section may cause permanent damage to the device. These are stress ratings only. Operating the module under these conditions, or any conditions other than those specified in the Operating Conditions section of the specifications, should be avoided. Prolonged exposure to Absolute Maximum Rating conditions may affect the device's reliability.

The operating condition range defines the limits within which the functionality of the device is guaranteed. While application information is provided, it is advisory only and does not form part of the specification.

Absolute Maximum Rating

Limiting values given below are in accordance with the Absolute Maximum Rating System (IEC 134).

Symbol	Description	Condition	Min.	Max.
3.3Vaux	Module supply voltage	Input DC voltage at 3.3Vaux pins	-0.3 V	3.6 V
USB	USB D+/D- pins	Input DC voltage at USB interface pins	-	3.6 V
RESET	RAK2287 reset input	Input DC voltage at RESET input pin	-0.3 V	3.6 V
SPI	SPI interface	Input DC voltage at SPI interface pin	-0.3 V	3.6 V
GPS_PPS	GPS 1 pps input	Input DC voltage at GPS_PPS input pin	-0.3 V	3.6 V
Rho_ANT	Antenna ruggedness	Output RF load mismatch ruggedness at ANT1	-	10:1 VSWR
Tstg	Storage Temperature	-	-40° C	85° C

WARNING

The product is not protected against overvoltage or reversed voltages. If necessary, voltage spikes exceeding the power supply voltage specification, as outlined in the table above, must be limited to values within the specified boundaries by using appropriate protection devices.

Maximum ESD

The table below lists the maximum ESD.

Parameter	Min	Typical	Max	Remarks
ESD_HBM			1000 V	Charged Device Model JESD22-C101 CLASS III
ESD_CDM			1000 V	Charged Device Model JESD22-C101 CLASS III

NOTE

Although this module is designed to be as robust as possible, electrostatic discharge (ESD) can damage this module. This module must be protected at all times from ESD when handling or transporting. Static charges may easily produce potentials of several kilovolts on the human body or equipment, which can discharge without detection. Industry-standard ESD handling precautions should be used at all times.

Power Consumption

Mode	Condition	Min.	Typical	Max.
Active-Mode (TX)	The power of TX channel is 27 dBm and 3.3 V supply.	511 mA	512 mA	513 mA
Active-Mode (RX)	TX disabled and RX enabled.	70 mA	81.6 mA	101 mA

Power Supply Range

The table below lists the power supply range.

Input voltage at **3.3Vaux** must be above the normal operating range minimum limit to switch-on the module.

Symbol	Parameter	Min.	Typical	Max.
3.3Vaux	Module supply operating input voltage ¹⁴	3 V	3.3 V	3.6 V

Mechanical Characteristics

The board weighs 16.3 grams, is 30 mm wide, and 50.96 mm tall. The dimensions of the module fall completely within the **PCI Express Mini Card Electromechanical Specification**, except for the card's thickness, which is 10.5 mm at its thickest point.

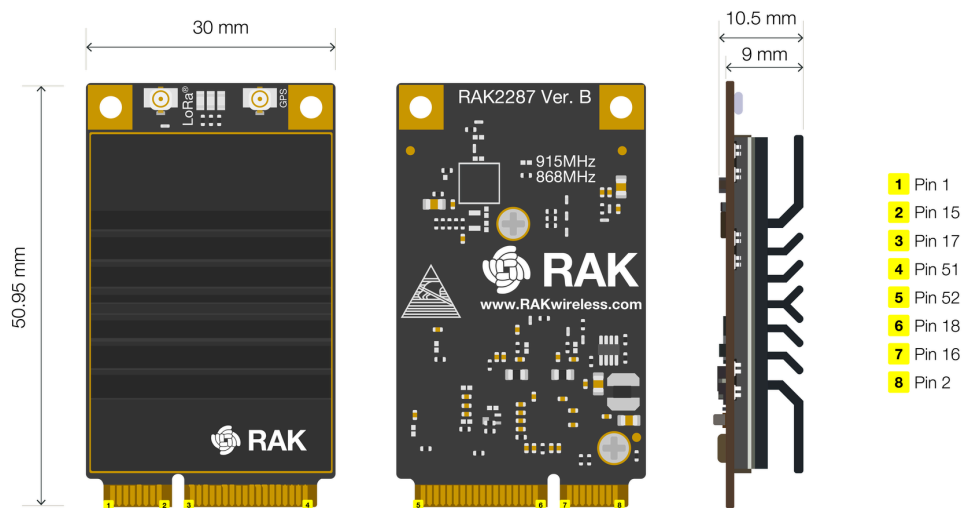

Figure 4: RAK2287 Board Dimensions

Environmental Requirements

Operating Conditions

The table below lists the operation temperature range.

Parameter	Min.	Typical	Max.	Remarks
Normal operating temperature	-40° C	+25° C	+85° C	Normal operating temperature range (fully functional and meet 3GPP specifications)

 **NOTE**

Unless otherwise indicated, all operating condition specifications are at an ambient temperature of 25° C. Operation beyond the operating conditions is not recommended and extended exposure beyond them may affect device reliability.

Schematic Diagram

The RAK2287 card is based on Semtech's reference design for the SX1302. The SPI interface is available on the PCIe connector. **Figure 5** illustrates the minimum application schematic for the RAK2287 card. It should be powered with at least 3.3 V / 1 A DC power and have the SPI interface connected to the main processor.

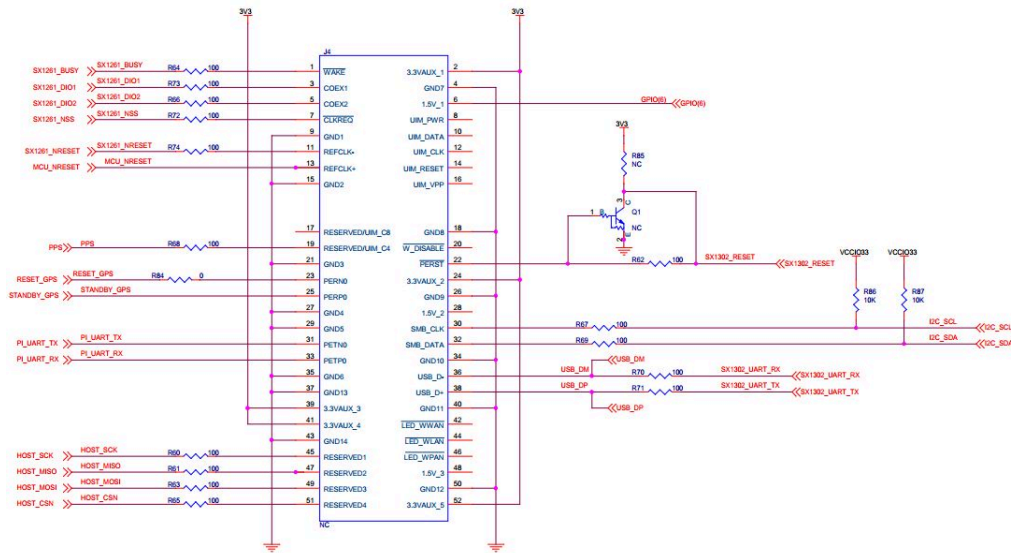

Figure 5: Schematic Diagram of RAK2287

Firmware

Download the latest firmware of the RAK2287 WisLink-LoRa in the table provided below.

Model	Raspberry Pi Board	Firmware Version	Source
RAK2287	Raspberry Pi 3B+, 4	v4.2.7R	Download

Models / Bundles

Order Information

In general, the variations of the RAK2287 are defined as **RAK2287 - XY**, where **X represents the model variant** and **Y indicates the supported region**. Refer to the tables below to understand the different variants and their specific specifications.

Parameter	Variations
X - Model Variant	S; M; A; C
Y - Supported Region	Selected from the frequency menu

The table below shows the board order configurations of the RAK2287 WisLink LPWAN Concentrator.

Model	SX1302 on board	STM32L412Kx on board	GPS module on board	SPI Interface	USB Interface
RAK2287-SY	√		√	√	

Model	SX1302 on board	STM32L412Kx on board	GPS module on board	SPI Interface	USB Interface
RAK2287-MY	√			√	
RAK2287-AY	√	√	√		√
RAK2287-CY	√	√			√

Certification

